

REVISIONS					
REV	ECR	DESCRIPTION	DATE	BY	APR
A	NPN	RELEASED FOR PRODUCTION	10-21-14	ANA	SAB

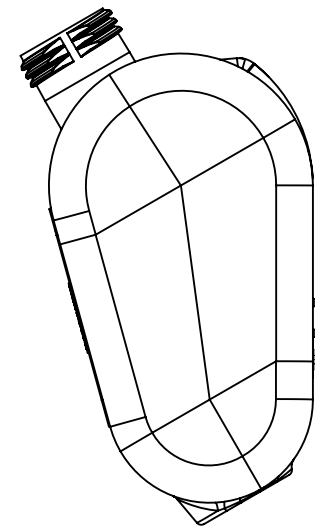
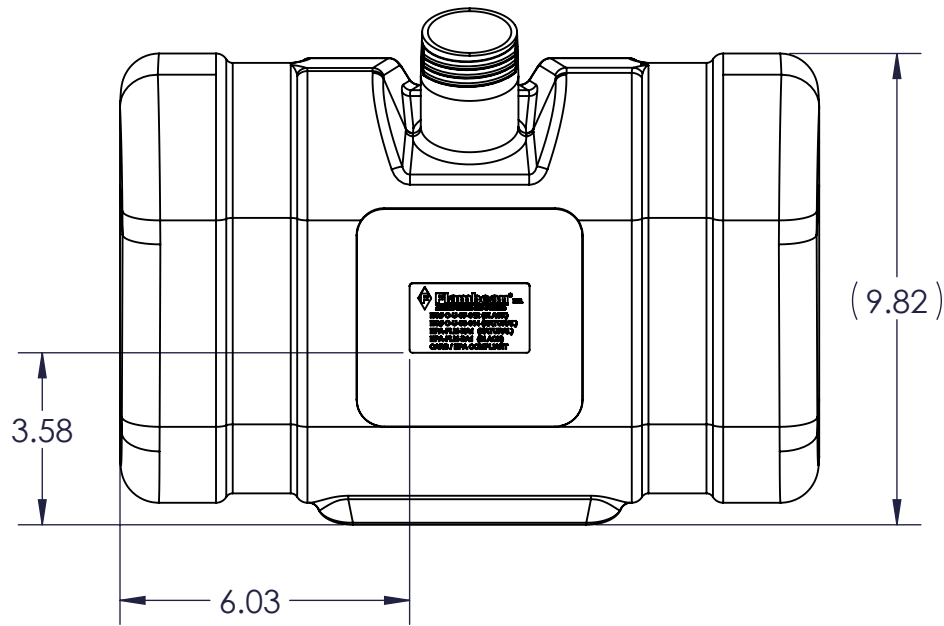
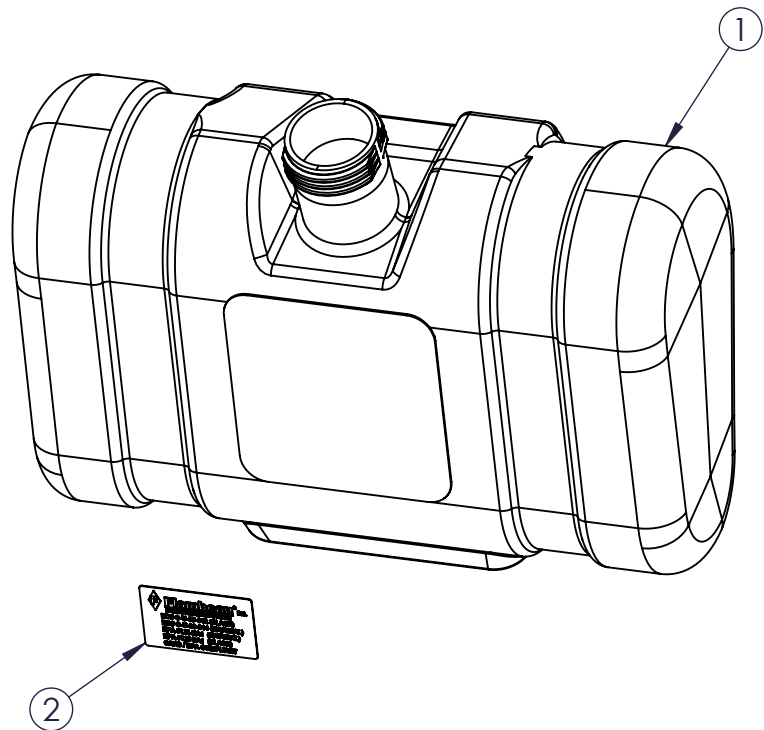
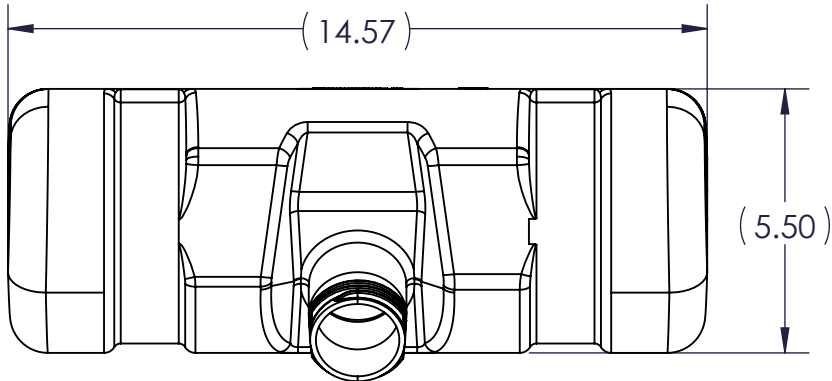

ITEM	FPN	DWG #	DESCRIPTION	QTY
2	477026x	477026	CARB/EPA FUEL TANK LABEL	1
1	070960A-FL	5685-1	2 GALLON TANK, CARB, BLACK	1

PROPRIETARY AND CONFIDENTIAL THE INFORMATION CONTAINED IN THIS DRAWING IS THE SOLE PROPERTY OF FLAMBEAU, INC. ANY REPRODUCTION IN PART OR AS A WHOLE WITHOUT THE WRITTEN PERMISSION OF FLAMBEAU, INC. IS PROHIBITED. DIMENSIONS ARE IN INCHES. THE FOLLOWING TOLERANCES APPLY UNLESS OTHERWISE SPECIFIED ANGULAR: ±3° TWO PLACE x.xx ±.125" THREE PLACE x.xxx ±.060" DIMENSIONS IN PARENTHESIS () ARE FOR REFERENCE ONLY.	SHT	FLAMBEAU, INC.		
	1	SCALE: 1:4	BFI NO: NA	DRAWN BY: ANA DATE: 10-21-14
	OF	MOLD NO: 5685	MAT'L: NA	FPN: 071400AE
	1	DESCRIPTION: TWO GALLON EPA/CARB FUEL TANK ASSEMBLY		
		CUSTOMER: US PLASTICS		DWG NO: 071400

CUSTOMER SIGN-OFF
COMPANY:
SIGNATURE:
PRINTED NAME:
DATE: